

Surgical Technique

Hansson Pinloc[®] 2

Swemac



FEMORAL NECK
FRACTURE SYSTEM

Hansson Pinloc® 2

Hansson Pinloc 2 is the second generation Hansson Pinloc implant; an innovative device for the treatment of femoral neck fractures.

The implant features three hook pins locked together by a plate and is an evolution of the long and successful experience with the Hansson Pin system. The Hansson Pinloc concept was developed to address the issue of fracture displacement after fixation and to reduce the risk of disruption to the femoral head blood supply.

By locking three hook pins and a plate into one dynamic unit, the pins are unable to rotate independently from one another as often occurs with isolated screws. In essence, the Hansson Pinloc 2 implant can **recreate the stability of an unbroken hip**. The clinical results are supportive and indicate that Hansson Pinloc 2 can reduce the occurrence of fracture healing complications.

Hook pin fixation

More than **350 000 patients** treated with the Hansson Pinloc, Hansson Pin or Hansson Twin Hook systems.

More than **280 scientific publications** and **10 Ph.D. theses** published on Hansson hook pin fixation technology.

Stability of an unbroken hip

Prevents
angulation

Prevents
rotation

Maintains
compression

Minimal surgical trauma

Preserves the
blood supply

Reduced risk of
secondary fracture

Minimal invasive
surgery

Product overview

The Hansson Pinloc 2 implant is part of the Swemac Femoral Neck Fracture System (FNF) and requires the FNF instrument platform for implantation. All implants are made from titanium alloy (Ti6Al4V) and delivered sterile for immediate use.

The implant consists of three cylindrical hook pins that are inserted through a locking plate into pre-drilled holes in the proximal femur. Fixation in the femoral head is achieved by pushing the inner sliding tongue out through the window of the outer pin.



Hook pins

The hook pins consist of three parts, an outer pin, an inner sliding tongue and a combined introduction and extraction screw. The diameter of a single pin is 6.5 mm and they are available in 2.5 mm increments from 70 to 130 mm.

Plates

Plates are available in three different sizes (6 mm, 8 mm and 10 mm), each with a CCD angle of 120° (angle between the pins and the plate). The sizing of the plates refers to the distance between the inferior pin and the proximal pins. The plate is triangular because in most cases it will need to be slightly rotated for the pins to fit the offset of the femoral neck from the femoral shaft.

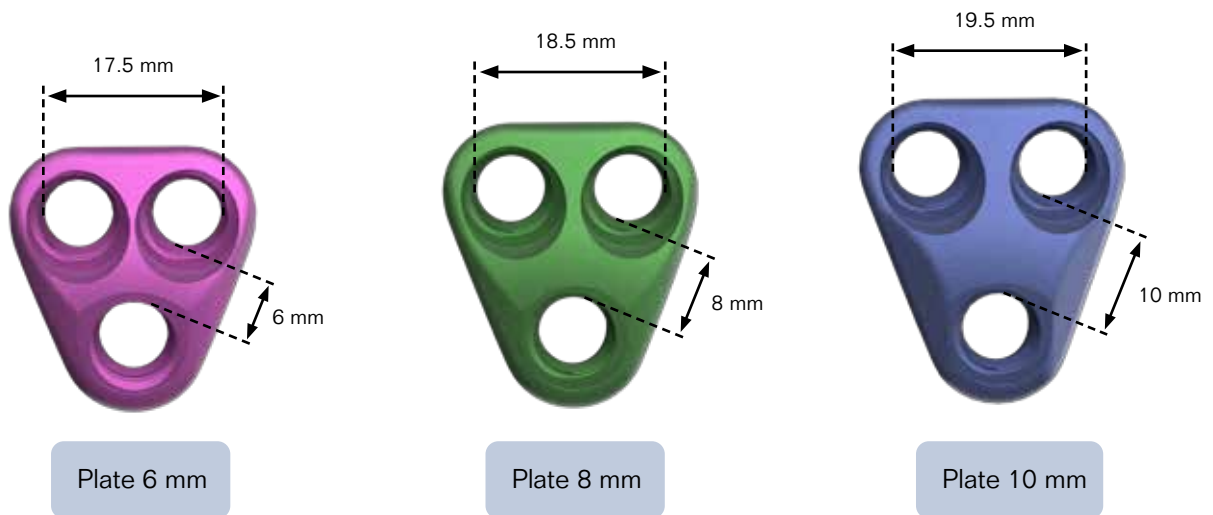

The fully assembled Hansson Pinloc 2 implant consists of 3 hook pins locked in the chosen plate. When fully assembled, the Hansson Pinloc 2 implant becomes one unit.

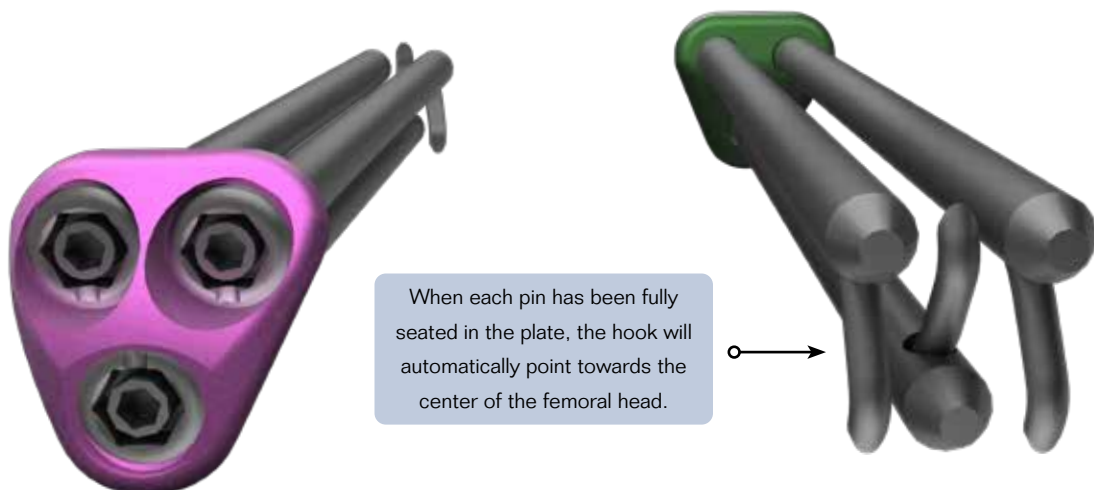

Pre-operative planning

Safe use of the Hansson Pinloc 2 implants requires the surgeon to have extensive knowledge about the indications and contraindications, the implants, the methods of application, the instrumentation and the recommended surgical technique of the device.

Indications

- Femoral neck fractures in adults

Contraindications

The surgeon's education, training and professional judgment must be relied upon to choose the most appropriate device and treatment. Conditions presenting an increased risk of failure include:

- Any active or suspected latent infection, sepsis or marked local inflammation in or around the surgical area.
- Material sensitivity, documented or suspected.
- Physical interference with other implants during implantation or use.
- Compromised vascularity, inadequate skin or neurovascular status.
- Compromised bone stock that cannot provide adequate support and/or fixation of the device due to disease, infection or prior implantation.
- Patients who are unwilling or incapable of following post-operative care instructions.
- Other physical, medical or surgical conditions that would preclude the potential benefit of surgery.
- Previously implanted or extracted osteosynthesis implants of the diaphyseal or proximal femur increases the risk of secondary fracture.
- Obesity. An obese patient can produce loads on the implant that can lead to device/treatment failure.
- Basal fractures of the femoral neck.

Caution: The surgeon must inform the patient about the use, limitations and possible adverse effects of the implants. The patient must also be warned that the implants/treatment might fail if they neglect the postoperative care instructions.

The principle

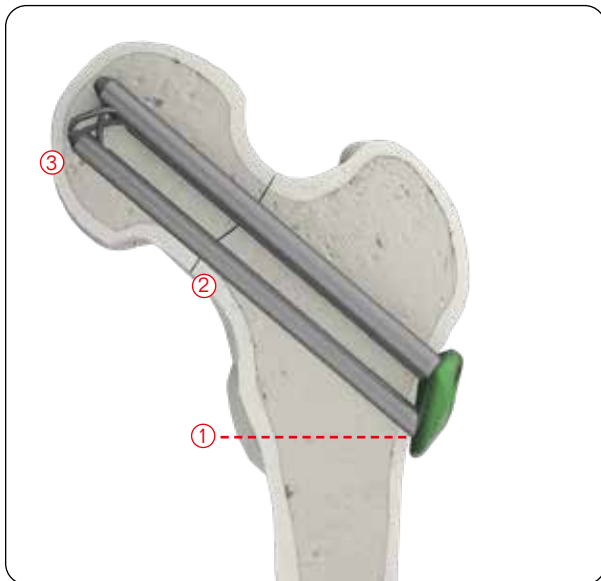

The inferior Pin (1-3).

The inferior Pin

1. Enters the lateral femoral cortex at a point opposite the lesser trochanter.
2. Touches the internal surface of the medial cortex in the femoral neck distal to the fracture.
3. Reaches the subchondral bone in the femoral head just below the centre.

The posterior Pin

The posterior Pin is placed parallel to the inferior Pin.

4. Enters the lateral femoral cortex.
5. Touches the internal surface of the posterior cortex of the femoral neck distal to the fracture.
6. Reaches the subchondral bone of the femoral head.

In a lateral x-ray projection the Pin is placed slightly posteriorly to the central femoral axis line.

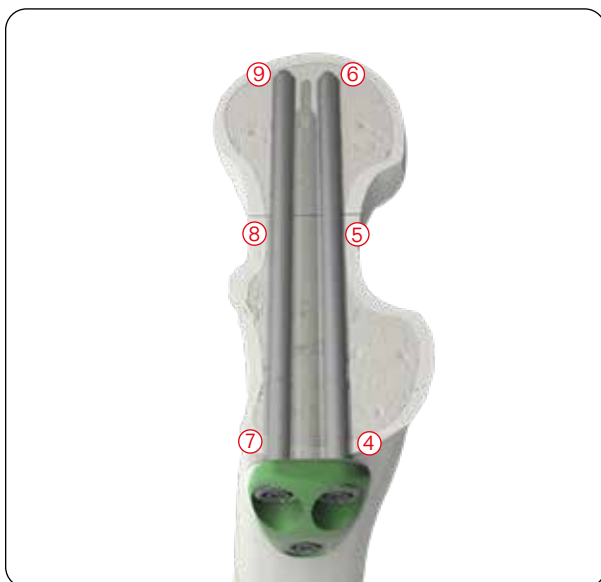

The posterior Pin (4-6) and the anterior Pin (7-9).

The anterior Pin

The anterior Pin is placed parallel to the posterior and the inferior Pin.

7. Enters the lateral femoral cortex.
8. Touches the internal surface of the anterior cortex (if possible) of the femoral neck distal to the fracture.
9. Reaches the subchondral bone of the femoral head.

In the lateral x-ray projection the Pin is placed slightly anteriorly to the central femoral axis line.

Surgical Technique

1. Patient positioning

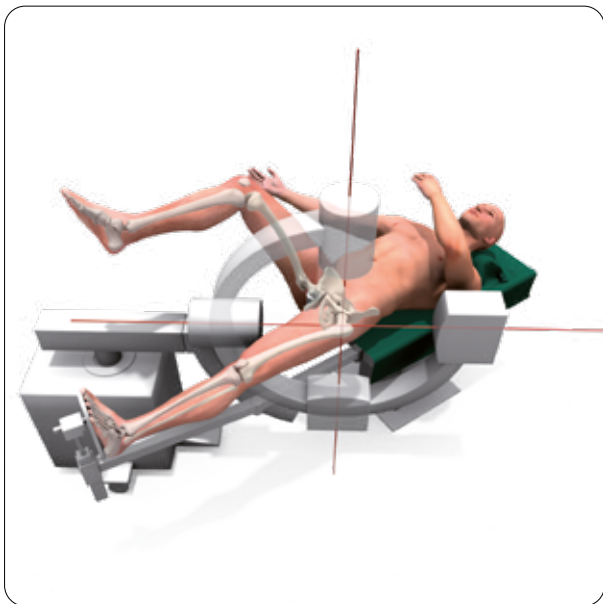

Place the patient supine on the fracture operating table. Position the unaffected leg with the hip in flexion and abduction to allow access for the C-arm. There must be enough room to allow for interoperative adjustments to achieve both an anteroposterior (AP) and a lateral view.

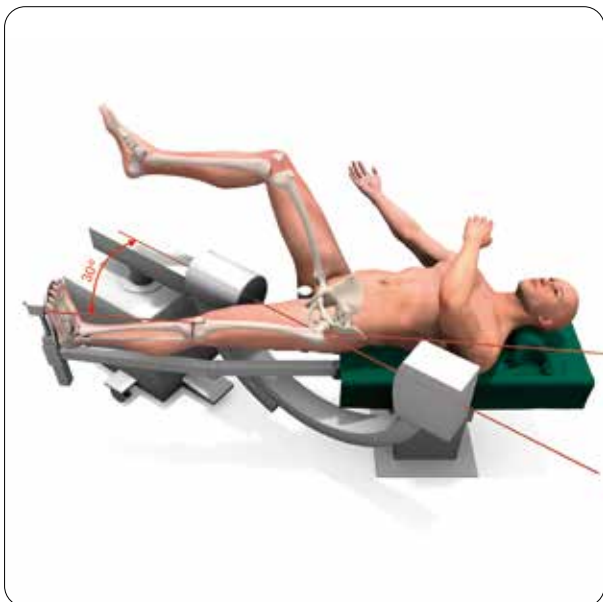

It is important to obtain a true lateral view of the femoral neck and the femoral head. This surgical technique will describe fixation of a femoral neck fracture using the Hansson Pinloc 2 implant.

2. Reduction

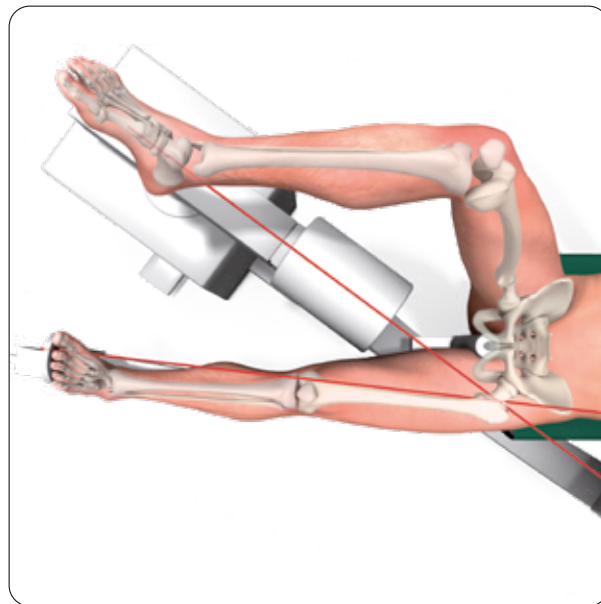

The fracture is reduced by longitudinal traction, abduction and internal rotation (if needed) on the fracture table. The fracture position should be in an anatomical position or with a slight valgus tilt. The proximal femur should ideally be positioned so that the head and the length axis of the neck are parallel to the floor.

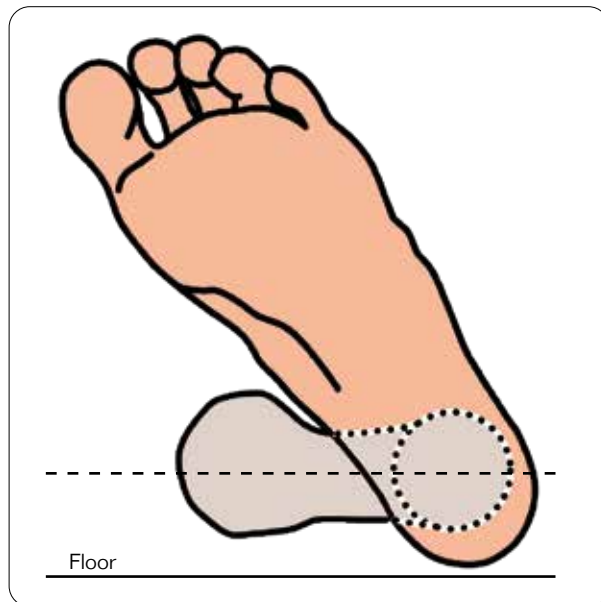

The patella should be in a horizontal or slightly internally rotated position. The patient should then be prepared and draped. In unstable fractures, Guide Wires can be placed to temporarily stabilise the reduced fragments.

3. Locate the optimal point for skin incision

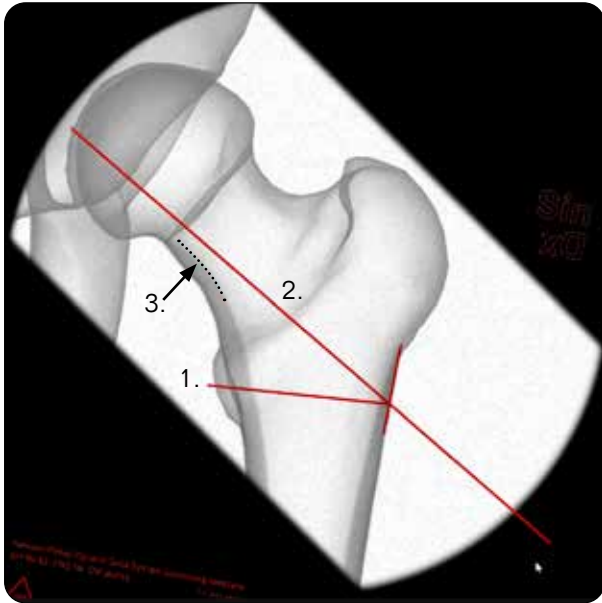

Place the Positioning Templates (62-3101 and 62-3102) onto the monitors of the image intensifier. The horizontal line (1) should be at the level, but not below, the lower edge of the lesser trochanter. It is essential to have the 120° line (2) close to the inner inferior cortex (3).

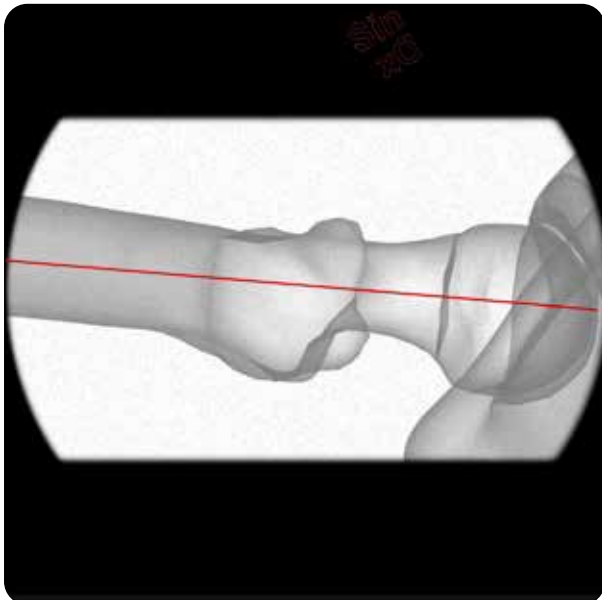

In the lateral view it is essential to place the template central in relation to the femoral neck and head.

Note: When using the Positioning Template, always lock the wheels of the image intensifier.

4. Make incision

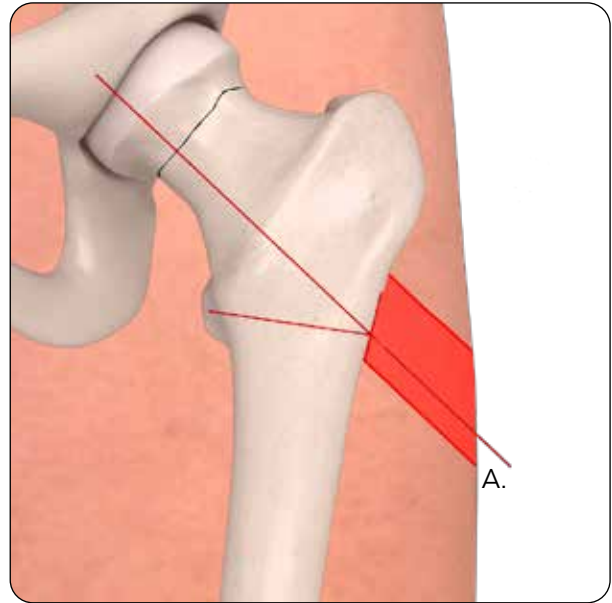

A longitudinal skin incision of approximately 40 mm is made in a cranial direction starting from point A. The deep fascia is divided in the direction of the fibres. The lateral cortex of the femur may be approached either directly or posterolaterally by elevating the vastus lateralis muscle. The area of the femur where the plate is to be positioned is cleared with a raspatorium.



The Guide Wire Sleeve Ø3.2 mm (62-4008) is inserted into the Plate Sizer (62-4018) and a Guide Wire Ø3.2 mm (72-2004) is selected. The Guide Wire Adapter with Quick-Lock (62-3034-3) can be used to facilitate the insertion of the optional Guide Wires Ø3.2 mm with Mini AO attachment (62-3004). It is possible to introduce the Guide Wire Adapter into the Drill Adapter with Quick-Lock (62-3094).

5. Introduce the Plate Sizer and the inferior Guide Wire

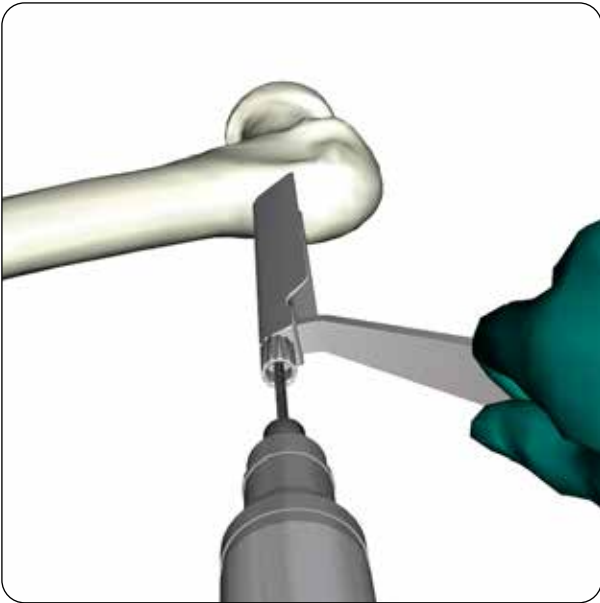

The Plate Sizer and the Guide Wire are introduced through the skin incision. Once the Guide Wire is aligned with the 120° line of the Positioning Template and the Plate Sizer is positioned parallel with the lateral cortex, the Guide Wire is advanced to the subchondral bone of the femoral head.

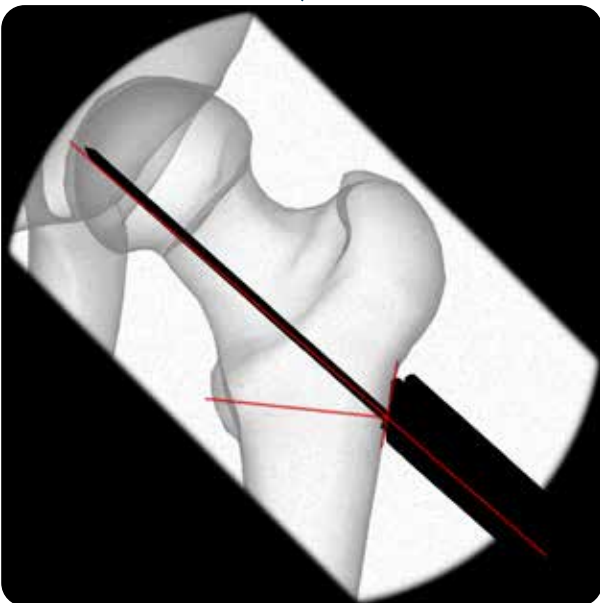

If the Guide Wire Sleeve is unable to make contact with the lateral cortex, the Plate Sizer should be removed and the area of the femur where the Plate Sizer is to be positioned is cleared with a raspatorium.

Note: The Guide Wire should not enter the lateral cortex distal to the lesser trochanter.

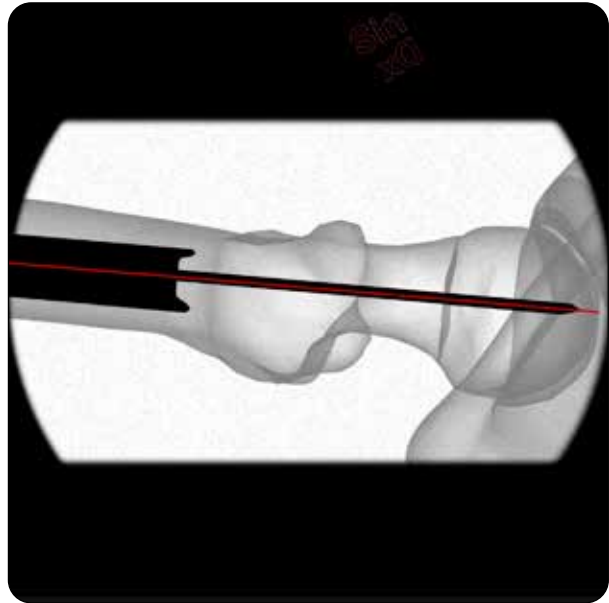

In the lateral view, the Guide Wire should be placed centrally in relation to the femoral neck and head.

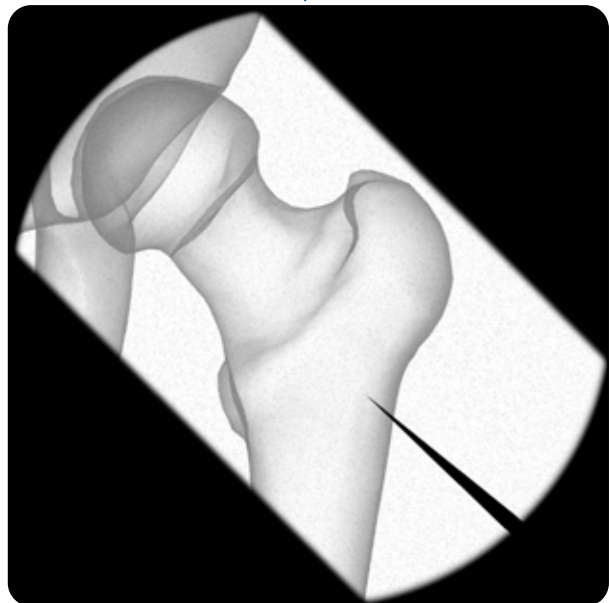

If the initial Guide Wire placement is not optimal, it is possible to enlarge the lateral cortex with the Awl (62-3070) to allow for angle adjustments without making additional holes in the lateral cortex.

Once optimum Guide Wire placement has been confirmed, the Guide Wire Sleeve and the Positioning Templates can be removed.

6. Drill the inferior canal

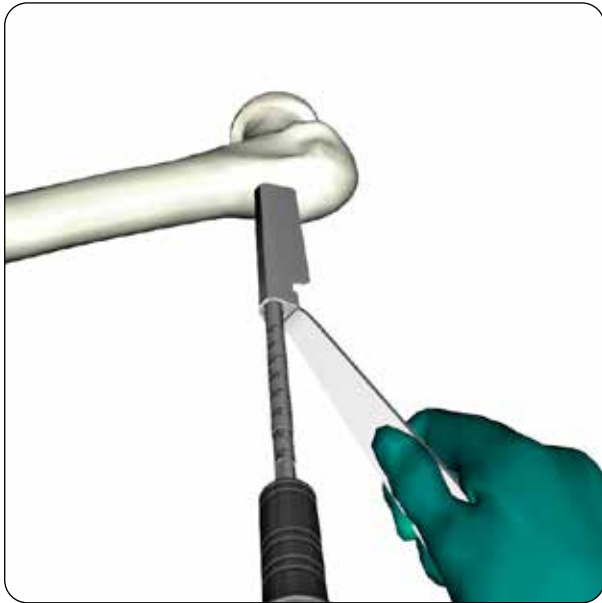

Introduce the Cannulated Drill Ø6.7 mm (62-4006) over the Guide Wire and through the Plate Sizer. The Drill Adapter with Quick-Lock should be used to facilitate the insertion of the drill. The drill is advanced to the subchondral bone of the femoral head.



Note: If drilling is carried out over a bent Guide Wire, there is a high risk of femoral head penetration.

7. Select the Plate

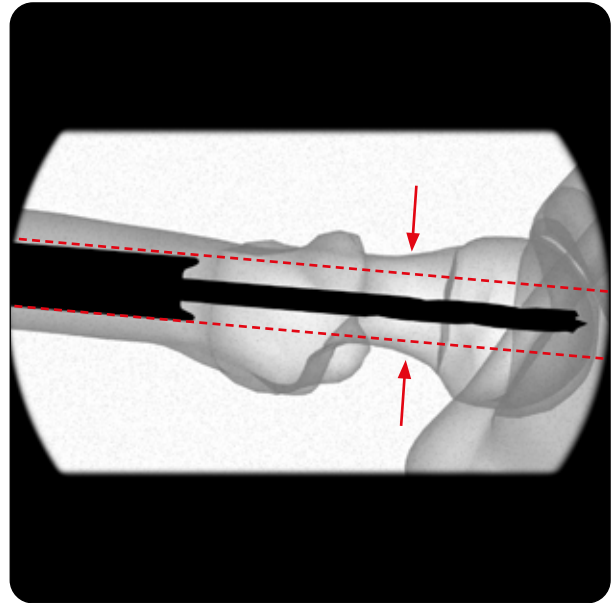

Select the Plate which gives the widest possible separation of the two proximal Pins without cutting through the posterior or anterior cortex of the femoral neck. The Plate Sizer has the same outer diameter as two proximal Pins mounted in a 8 mm Plate. Based on this assessment, the correct Plate can be selected.

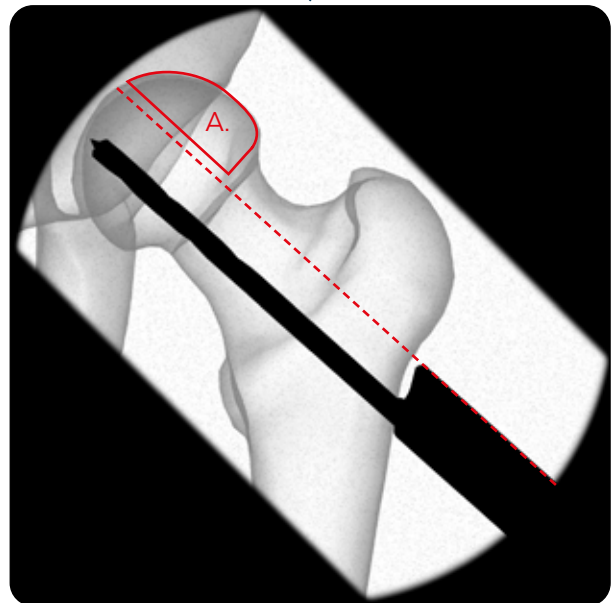

In the AP view the proximal Pins should be positioned just above the center of the femoral neck and head. It is important to avoid the area labelled (A) in order to preserve the blood supply to the femoral head.

Note: If between sizes, always choose the smaller Plate

8. Assemble the Targeting Guide

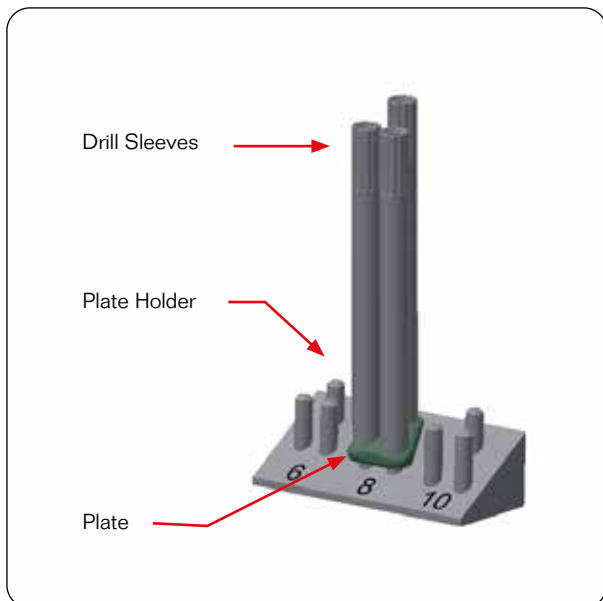

Place the chosen Plate on the corresponding plate holder inside the instrument set. Introduce the three Drill Sleeves $\text{Ø}6.7$ mm (62-4010) over the pegs into the threaded holes of the selected plate. The T-handle 6.0 mm HEX (62-4022) is used to tighten the Drill Sleeves.

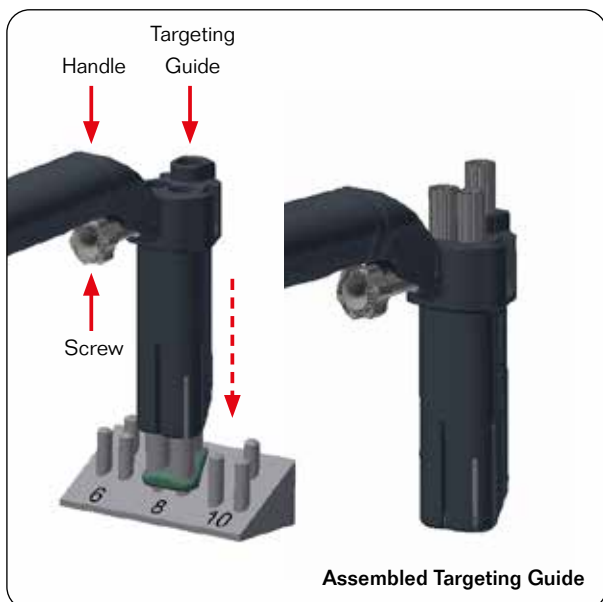

Slide the Handle (62-3122) into one of the three slots on the top of the Targeting Guide (depending on the surgeon's preference) and secure it using the Screw (62-3125).

Push the Targeting Guide (62-3114, 62-3116 or 62-3118) over the Drill Sleeves. This will lock the Targeting Guide to the Plate.

9. Drill the posterior canal

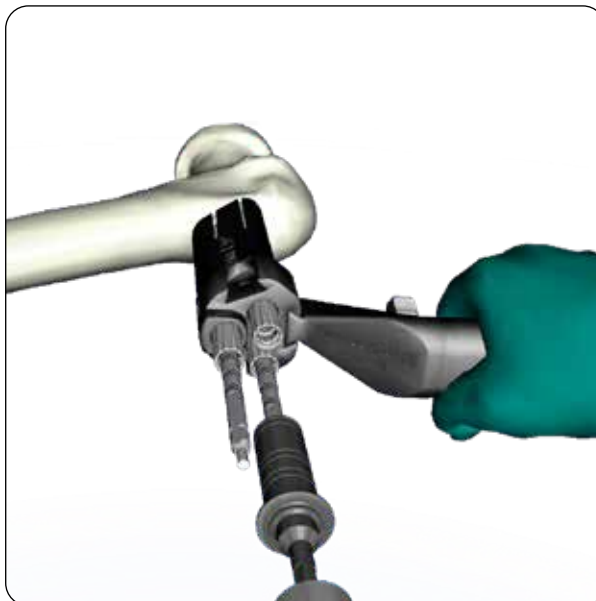

The assembled Targeting Guide is introduced over the inferior Drill. The Solid Drill $\text{Ø}6.7$ mm (62-4004) is introduced into the posterior Drill Sleeve.

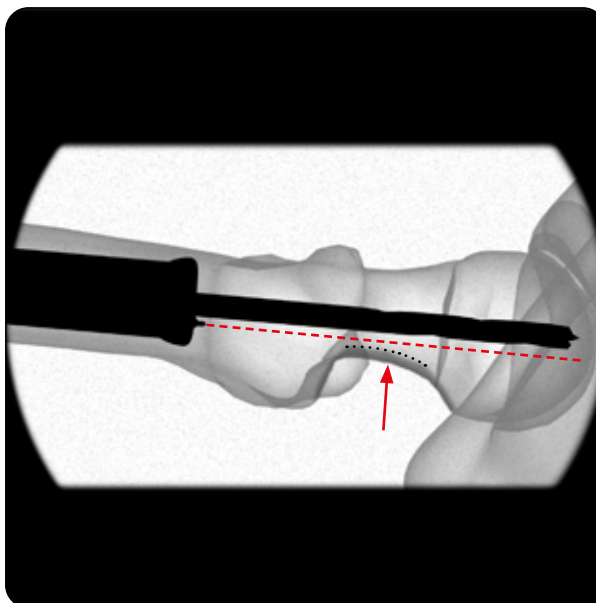

It is important to slightly rotate the Targeting Guide so that the Solid Drill will touch the internal posterior cortex of the femoral neck.

Optional: Using a Guide Wire

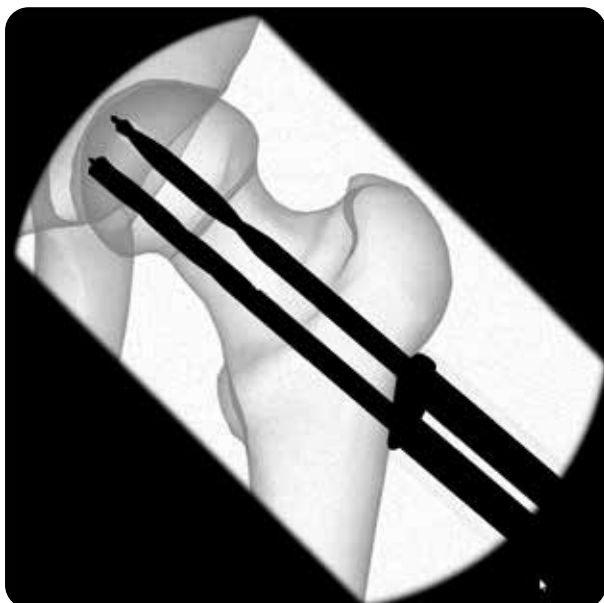

The Solid Drill is advanced to the subchondral bone of the femoral head.

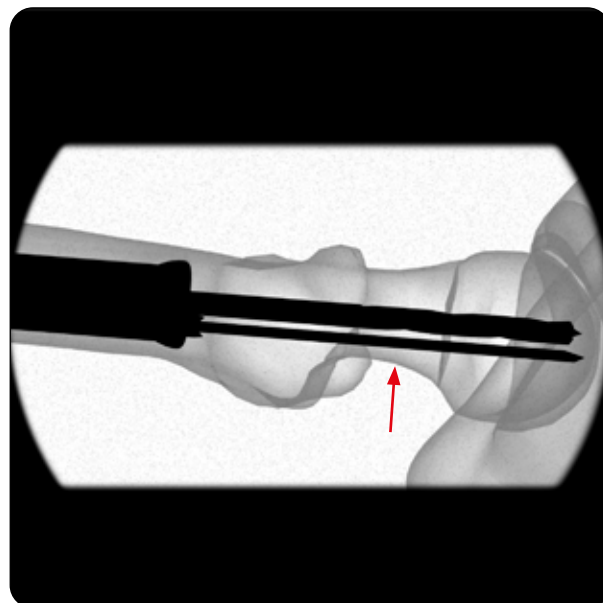

A posterior Guide Wire can be introduced to check the position at the femoral neck before drilling is carried out with a Cannulated Drill. The Guide Wire Sleeve is inserted into the posterior Drill Sleeve to facilitate the insertion of the Guide Wire. Once the alignment of the Guide Wire is satisfactory, the Guide Wire is advanced to the subchondral bone of the femoral head.

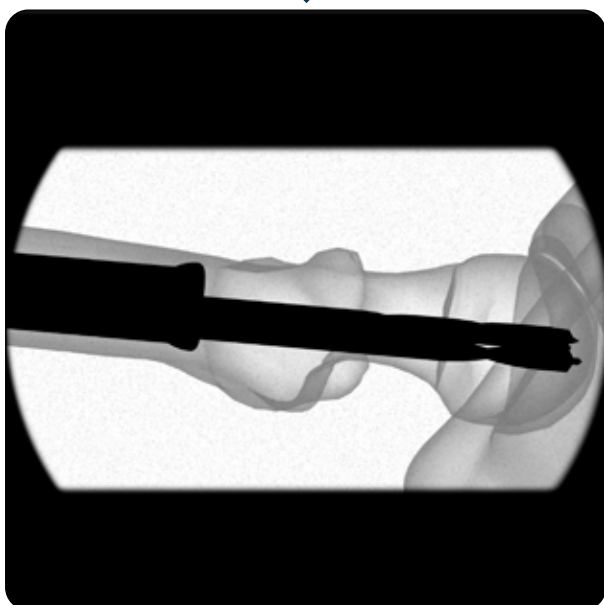

The rotation of the Targeting Guide and the Plate are now locked at the lateral cortex and they cannot rotate anymore. This means that the direction of the anterior drill cannot be changed.

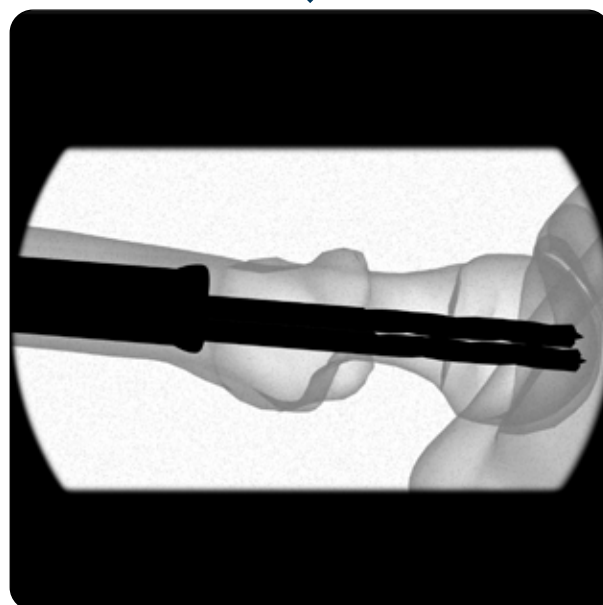

The Cannulated Drill is introduced over the Guide Wire and advanced to the subchondral bone of the femoral head.

10. Drill the anterior canal

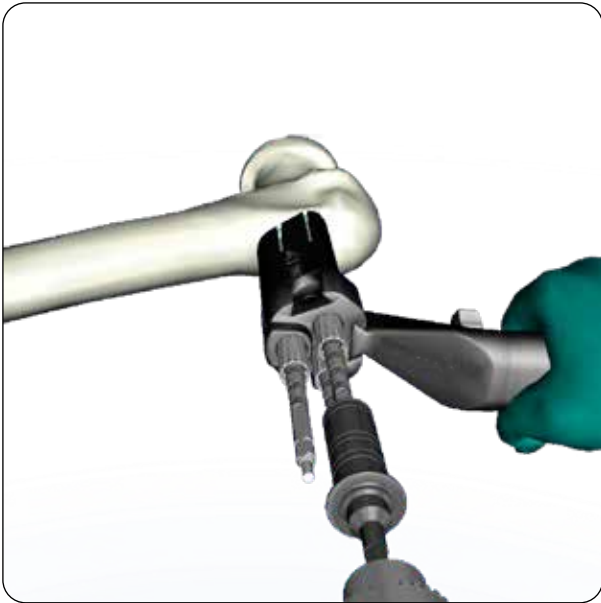

The Solid Drill Ø6.7 mm is introduced into the anterior Drill Sleeve and advanced to the subchondral bone of the femoral head.

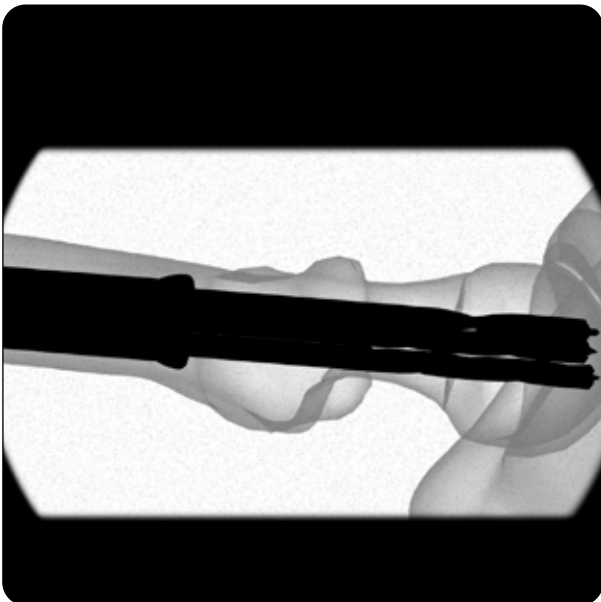

11. Reduce traction on the operating table

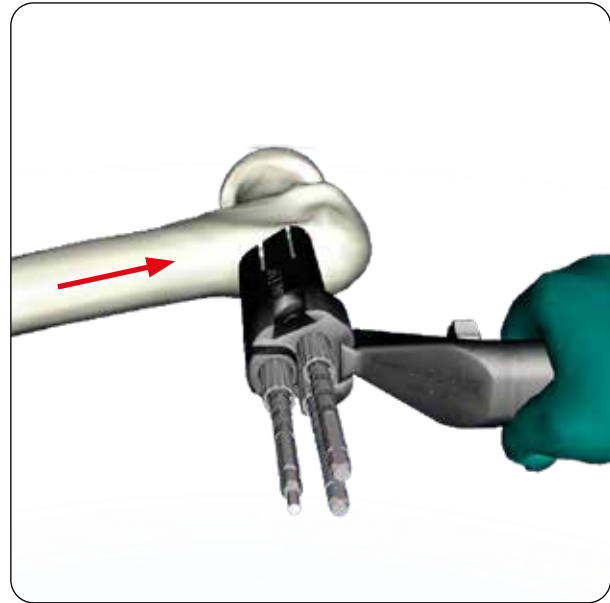

By reducing traction on the operating table, it is possible to compress the fracture in the axis of the femoral neck. The surgeon can simultaneously push the handle of the Targeting Guide forward to compress the fracture even further.

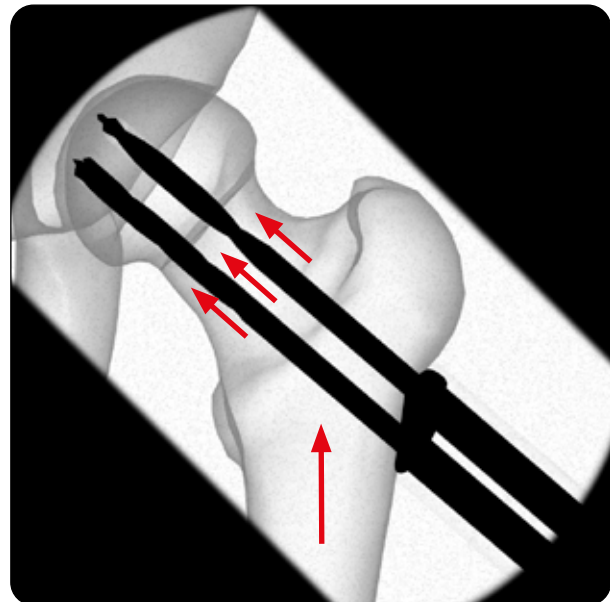

The drills will maintain the fracture reduction. This step will minimise unnecessary post-operative lateralisation of the Plate.

Note: Do not hammer on the Handle or the Targeting Guide

12. Measure the required Pin length for the inferior canal

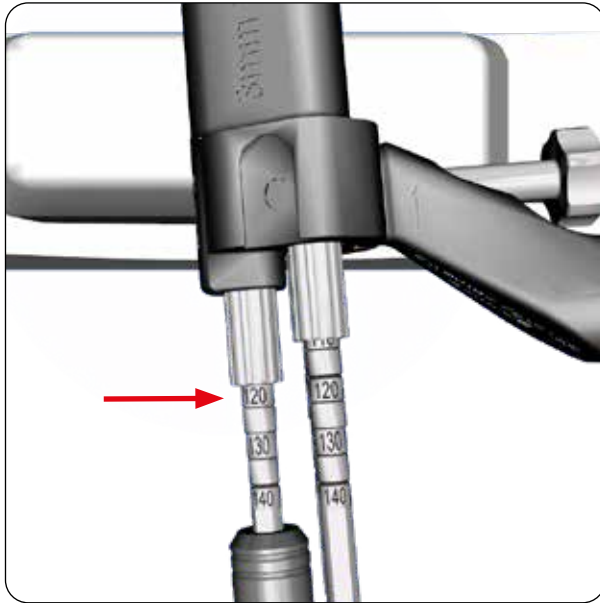

The required Pin length is read off the scale on the drill against the end of the inferior Drill Sleeve. If the measured value is between two pin lengths, the drilling depth can be adjusted by attaching the Handle with Quick-Lock (62-3092) to the Cannulated Drill. Make sure that the Plate is in contact with the lateral cortex of the femur when reading the scale.

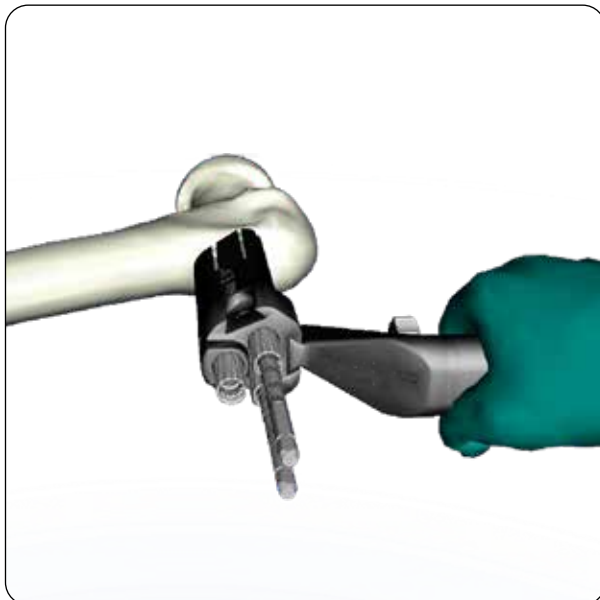

The Handle with Quick-Lock can be used to remove the Cannulated Drill. The inferior Cannulated Drill should always be removed before removing the inferior Drill Sleeve. This will minimize the risk of the drill damaging the internal threads of the Plate. It will also make sure that the threads in the Plate are clean from bone debris.

13. Instrument-to-implant Assembly

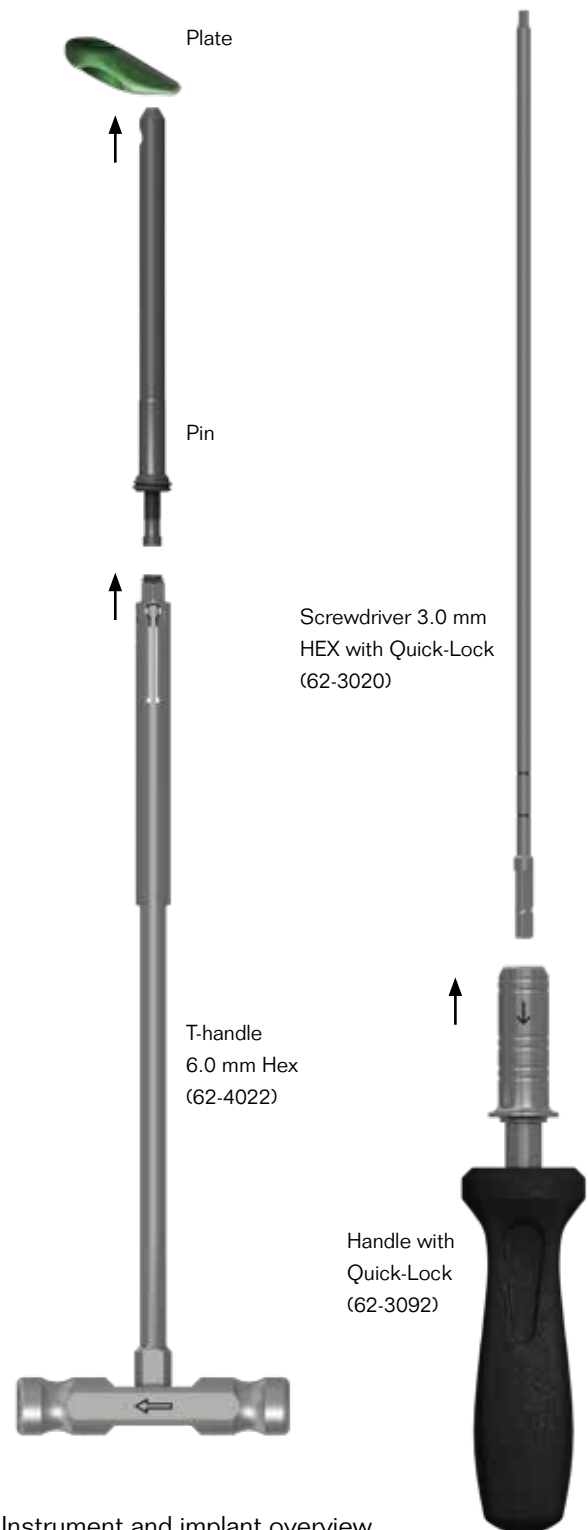

Instrument and implant overview.

14. Assemble the T-handle 6.0 mm Hex and the chosen Pin

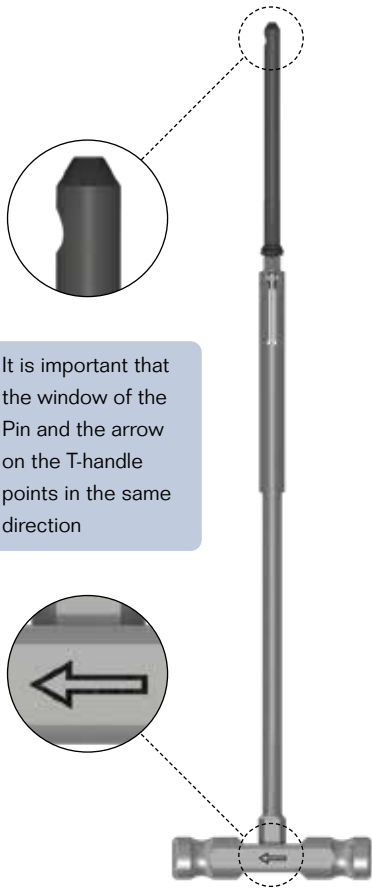

It is important that the window of the Pin and the arrow on the T-handle points in the same direction

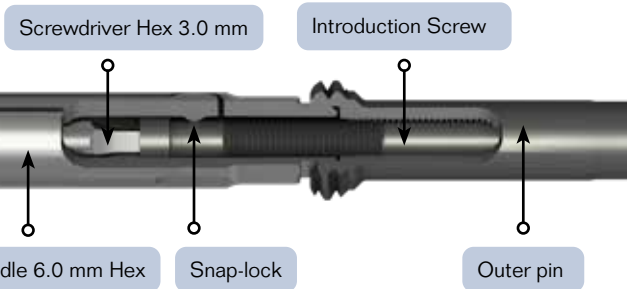

The T-handle 6,0 mm Hex is introduced into the Pin which will snap and lock into place.

15. Introduce the inferior Pin

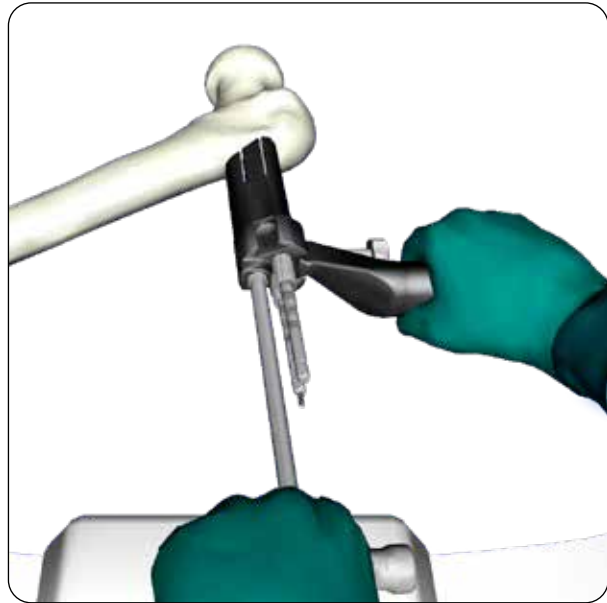

The selected size of Pin for the inferior canal is mounted on the Handle and inserted. The Handle is turned clockwise as far as it will go.

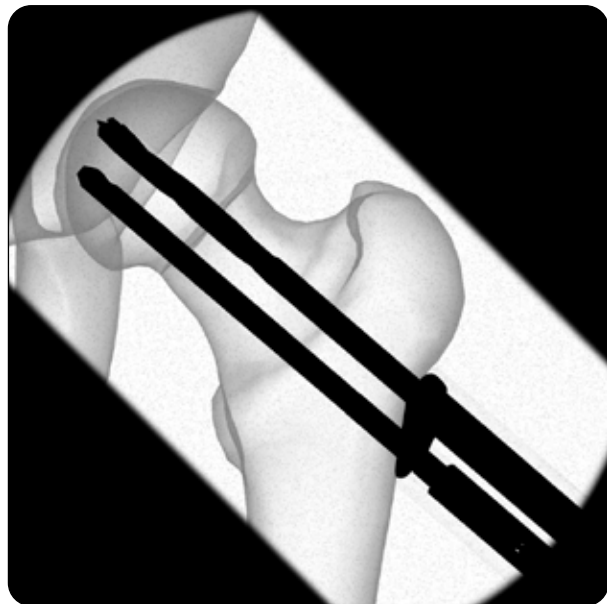

When the Pin is properly locked in the Plate, the hook will automatically point towards the center of the femoral head. Ensure that the Pin is fully inserted and in good position using image intensification. The Handle is left in position.

16. Assemble the Screwdriver Hex and the Handle with Quick-Lock



Insert the tip of the assembled screwdriver through the hole in the T-handle 6.0 mm Hex.

17. Deploy the hook of the inferior Pin

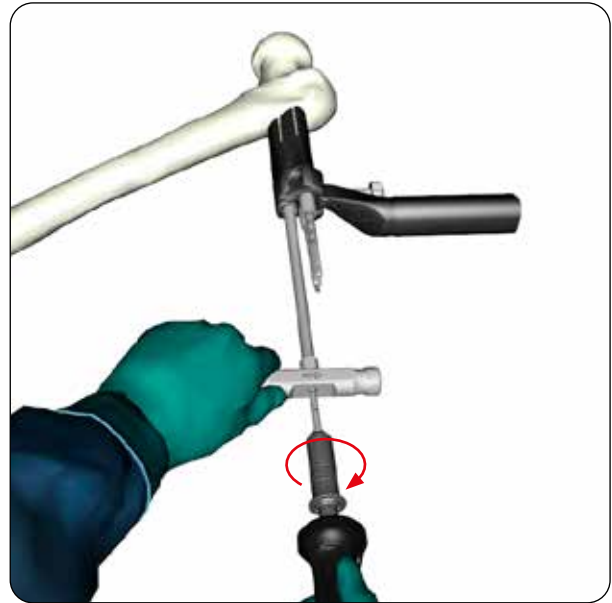

The hook is deployed by turning the assembled screwdriver clockwise whilst pushing medially on the T-handle.

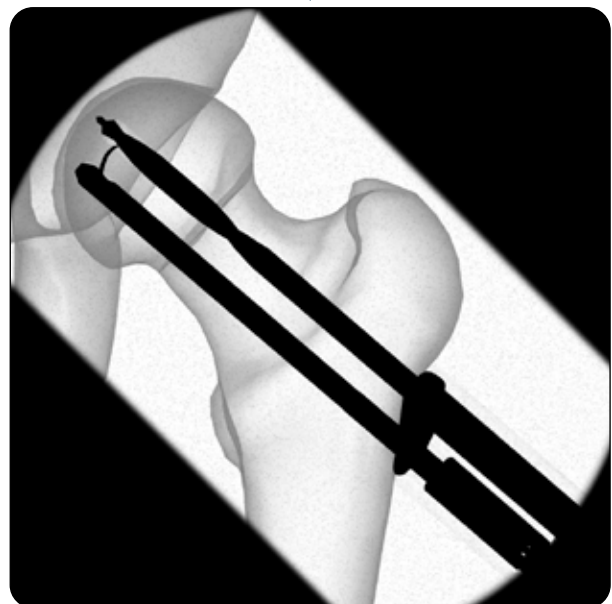

The hook is fully extruded when the introduction screw reaches its mechanical stop. Check the position of the hook under image intensification. After deployment of the hook, the introducer assembly shall be removed. (This step can also be done as the last step after introducing all three pins).

Note: Do not over-tighten the introduction screw. Make sure that the hook did not penetrate the femoral head.

18. Introduce the posterior Pin and then the anterior Pin

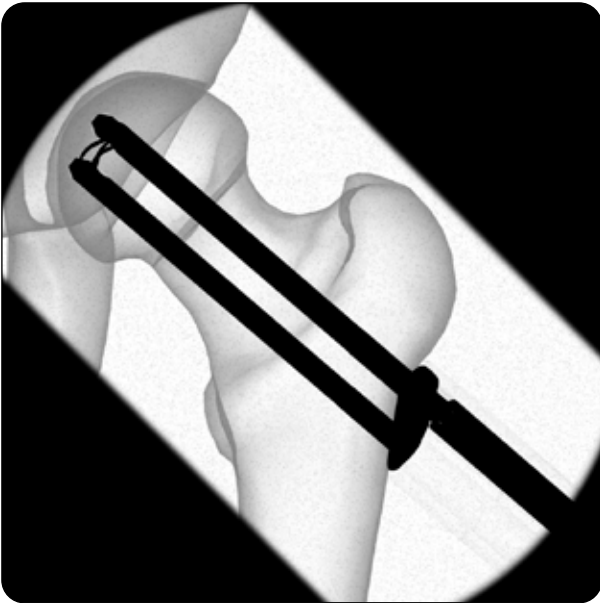

The same procedure to measure and introduce the inferior Pin (steps 12-17) are repeated for the posterior and anterior Pin.



Use the T-handle 6.0 mm Hex to push the Plate against the lateral cortex when removing the Targeting Guide. This will help to disengage the Targeting Guide without disturbing the implant position.

Check the position of the Pins



Before closing the skin incision, it is important to make sure that none of the Pins have penetrated the joint. This can be done by releasing traction and rotating the hip under image intensification in both AP and lateral view.

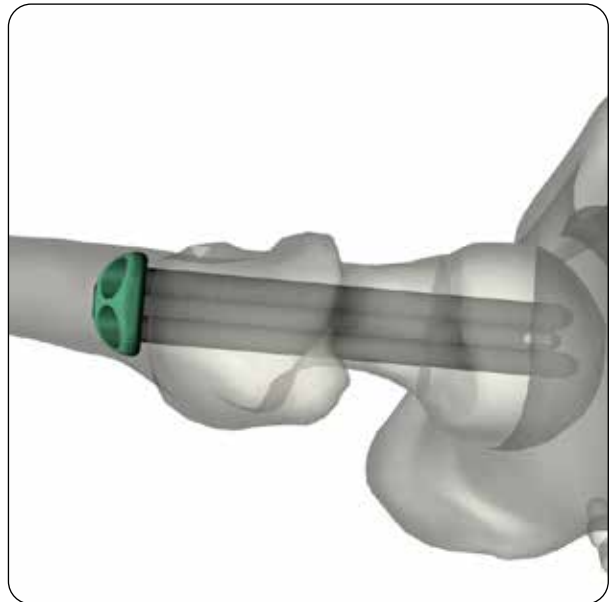

Implant extraction

1. Retract the hook of the inferior Pin

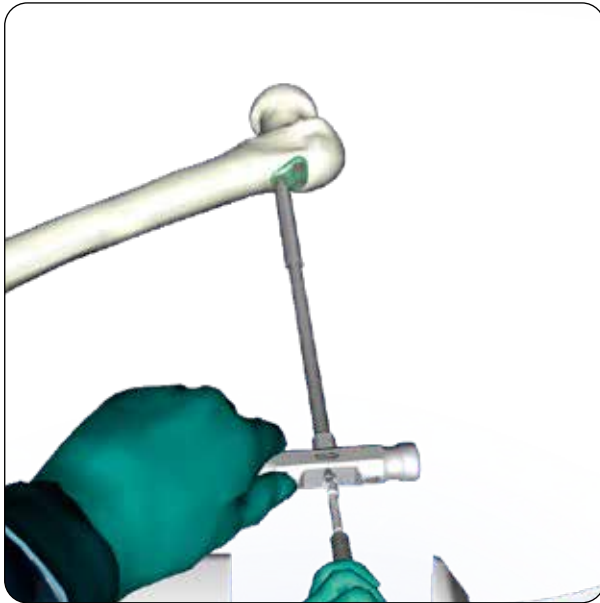
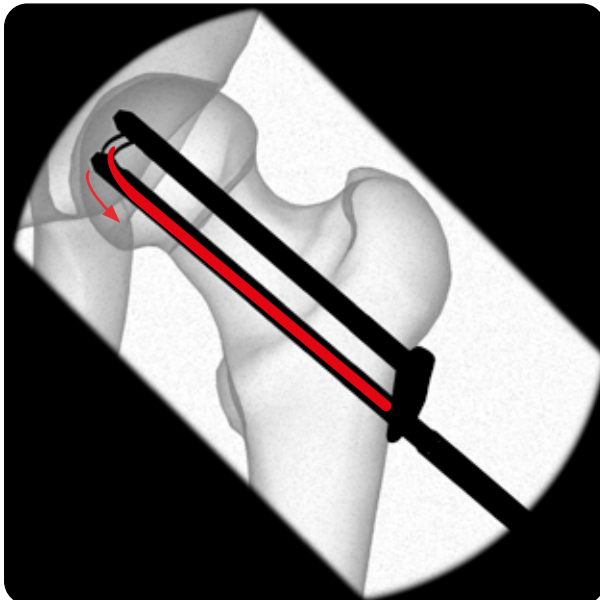
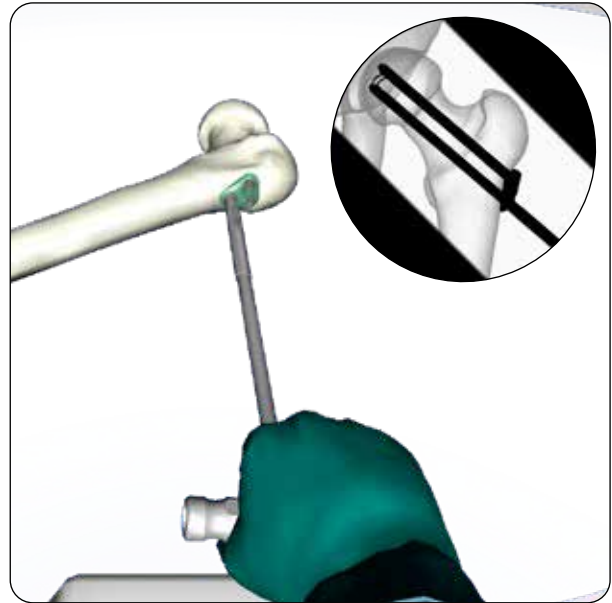

Image intensification is used to locate the Plate and a skin incision of approximately 40 mm is made. The T-handle 6.0 mm Hex is introduced into the inferior Pin. The Screwdriver Hex $\text{\O}3.0$ mm and the Handle with Quick-Lock are assembled.



The assembled screwdriver is introduced into the T-handle 6.0 mm Hex and rotated counter-clockwise to retract the hook.

2. Remove the inferior Pin



Check under image intensification that the hook is fully retracted prior to the removal of the Pin. The Pin is removed by rotating the T-handle 6.0 mm Hex counter-clockwise. The Pin Remover (62-3064) can be used to pull out the Pin.

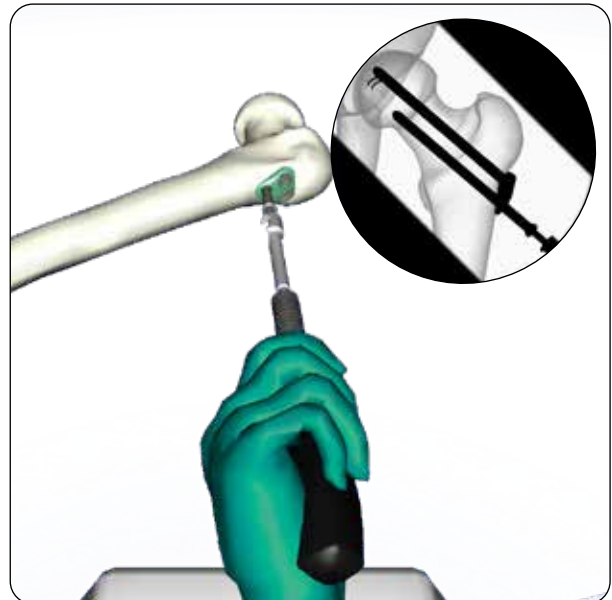

The same procedure as used when removing the inferior Pin (steps 1-2) is repeated when removing the posterior and finally the anterior Pin.

In patients with poor bone quality, it is possible to remove the Plate together with all Pins after retraction of the hooks.

Note: A special dedicated extraction instrument set is available at Swemac in the case of broken or damaged implants.

Product information

All implants are delivered sterile.

Part of the Swemac Femoral Neck Fracture System (FNF)

Implants











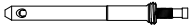
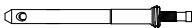

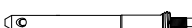





Pin Length 70 mm	62-1070S	
Pin Length 72.5 mm	62-1072S	
Pin Length 75 mm	62-1075S	
Pin Length 77.5 mm	62-1077S	
Pin Length 80 mm	62-1080S	
Pin Length 82.5 mm	62-1082S	
Pin Length 85 mm	62-1085S	
Pin Length 87.5 mm	62-1087S	
Pin Length 90 mm	62-1090S	
Pin Length 92.5 mm	62-1092S	
Pin Length 95 mm	62-1095S	
Pin Length 97.5 mm	62-1097S	
Pin Length 100 mm	62-1100S	
Pin Length 102.5 mm	62-1102S	
Pin Length 105 mm	62-1105S	
Pin Length 107.5 mm	62-1107S	
Pin Length 110 mm	62-1110S	
Pin Length 112.5 mm	62-1112S	
Pin Length 115 mm	62-1115S	
Pin Length 117.5 mm	62-1117S	
Pin Length 120 mm	62-1120S	
Pin Length 122.5 mm	62-1122S	
Pin Length 125 mm	62-1125S	
Pin Length 127.5 mm	62-1127S	
Pin Length 130 mm	62-1130S	

Plate | 120° | 6 mm

62-2106S

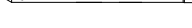

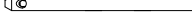
Plate | 120° | 8 mm

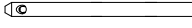
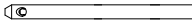
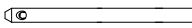
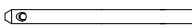
62-2108S



Plate | 120° | 10 mm

62-2110S



Instruments

Guide Wire Ø3.2 mm Length 300 mm	72-2004
Guide Wire with Mini AO Ø3.2 mm Length 300 mm	62-3004N
Guide Wire with Mini AO Ø3.2 mm Length 300 mm	62-3004S
Screwdriver 3.0 mm HEX with Quick-Lock	62-3020
Guide Wire Adapter with Quick-Lock	62-3034-3
Pin Remover	62-3064
Awl	62-3070
Handle with Quick-Lock	62-3092
Drill Adapter with Quick-Lock	62-3094
Targeting Guide 6 mm 120°	62-3114
Targeting Guide 8 mm 120°	62-3116
Targeting Guide 10 mm 120°	62-3118
Handle – To Targeting Guide	62-3122
Screw – To Targeting Guide	62-3125
Solid Drill Ø6.7 mm Length 294 mm	62-4004
Cannulated Drill Ø6.7 mm Length 291 mm	62-4006
Guide Wire Sleeve Ø3.2 mm – To Targeting guide	62-4008
Drill Sleeve Ø6.7 mm – To Targeting guide	62-4010
T-handle 6.0 mm HEX – To Targeting guide	62-4022
Plate Sizer	62-4018
Drill Sleeve Ø6.7 mm with Handle	62-4038
Guide Wire Sleeve Ø3.2 mm with Handle	62-3036
Solid Stepdrill Ø6.7 mm Length 291 mm	150-3013
Cannulated Stepdrill Ø6.7mm Length 291 mm	150-3016
Screw Holder	150-3069
Swemac FNF System - Instrument tray	62-1001

Hansson Pinloc 2 instruments

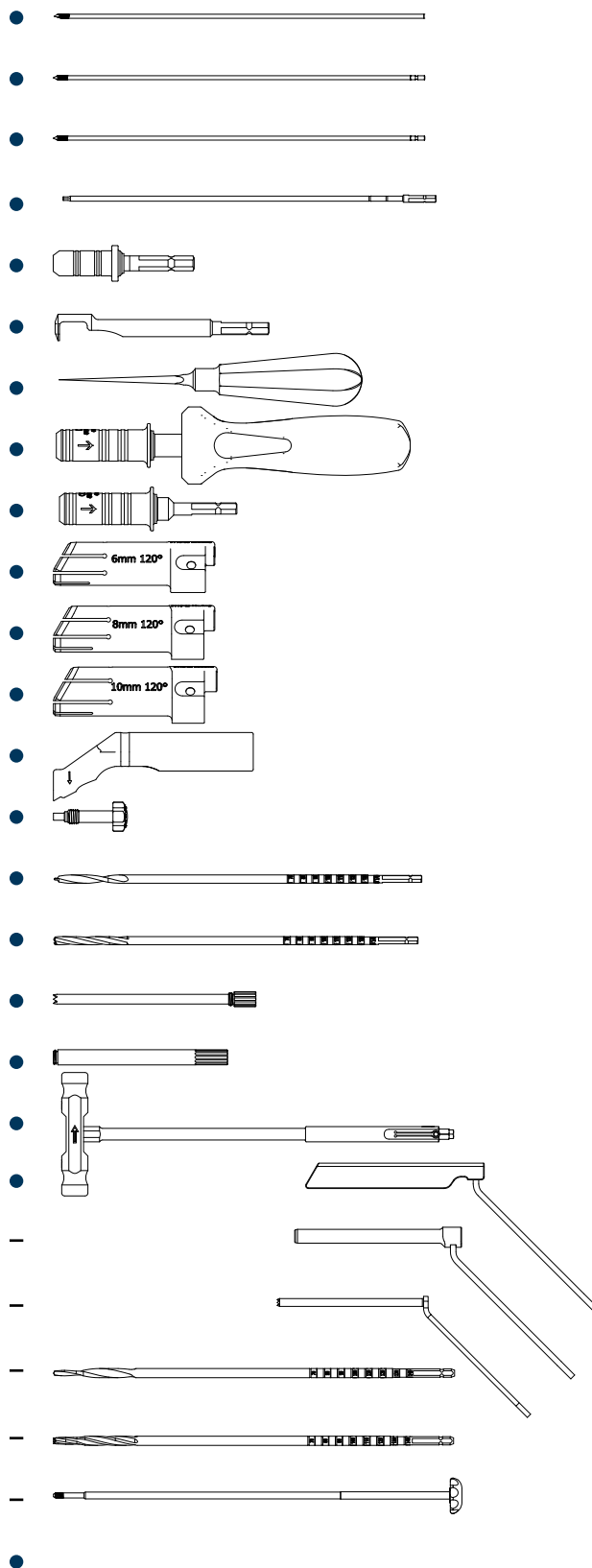

Hansson Pin Positioning Template 120° 62-3102 ●

Positioning Template (AP & lateral view) | Straight line 62-3101 ●

Below shows the complete Swemac FNF instrument tray required to implant the Hansson Pinloc 2.

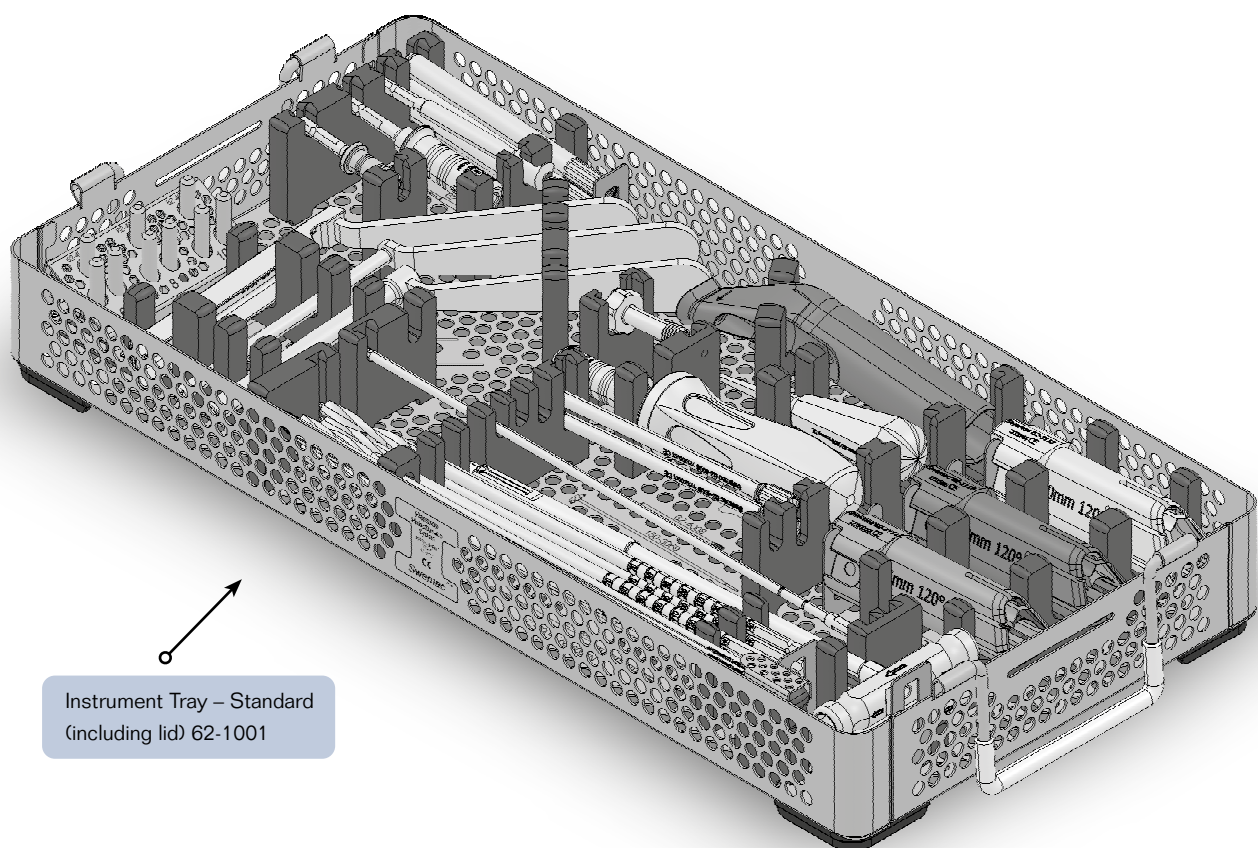

IFU

For the latest version of this Instruction For Use. Please visit:
download.swemac.com/Hansson-Pinloc-System

Swemac

Hansson Pinloc® 2 System

Manufacturer: **Swemac Innovation AB**   0413
Cobolgatan 1 • SE-583 35 Linköping, Sweden
+46 13 37 40 30 • info@swemac.com
www.swemac.com

P102-28-2-20210413
Print date: 2021-04-13